

CHEMICAL METERING SYSTEMS

Improve your process, simplify your installation



Peristaltic chemical metering systems from the

NEW

TURN-KEY PERISTALTIC SOLUTIONS FROM THE MARKET LEADER

Watson-Marlow, the world leader in peristaltic pumps, introduces its new range of engineered chemical metering systems. Building on over 50 years of pump experience, these turn-key systems are designed to save time and money by providing a complete chemical metering solution.

All chemical metering systems come complete with a Watson-Marlow peristaltic pump at its core. Offering unparalleled performance, simple maintenance and worldwide support, each system is designed to perform in the toughest applications and environments.

By combining the pumps, gauges, columns and other system accessories into a complete system, Watson-Marlow provides a robust metering solution from a single source, backed by expertise from the market leader in peristaltic chemical metering.

Benefits

- Fully integrated and tested systems that save installation time and costs
- A single source for total system support
- Designed and engineered by the market leader in peristaltic metering
- Robust and flexible design for optimal system integration
- Paint-free corrosion resistant polypropylene construction



Applications

- Disinfection
- pH adjustment
- Flocculation
- Industrial cooling
- Reagent dosing

market leader

Watson-Marlow offers four standard chemical metering system configurations: single pump, dual pump (duty/standby), dual pump (dual discharge), and triple pump (triple discharge). Each peristaltic skid features provisions for pressure relief, pump isolation and fluid calibration as standard without the need for degassing valves, strainers, back pressure valves, pulsation dampeners or other ancillary items typically found on complicated and expensive diaphragm pump systems. All Watson-Marlow systems are fully tested and include complete documentation.

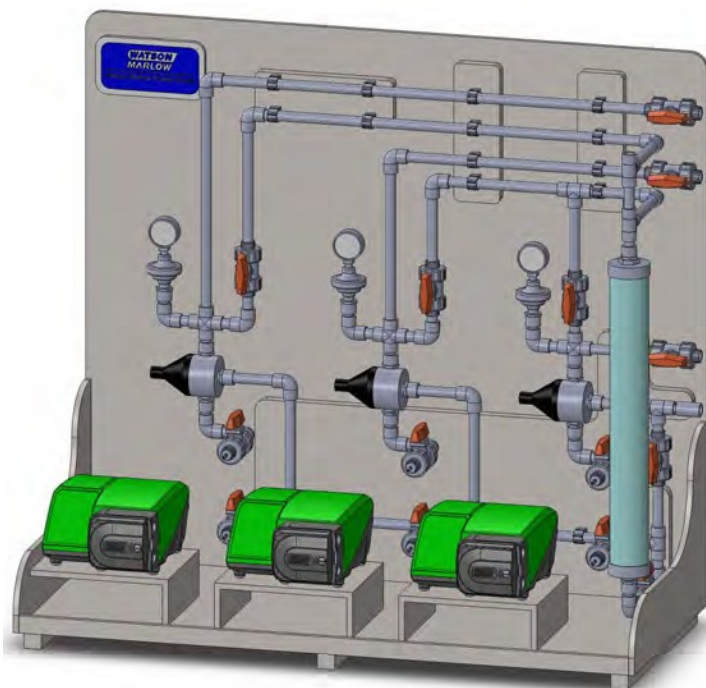
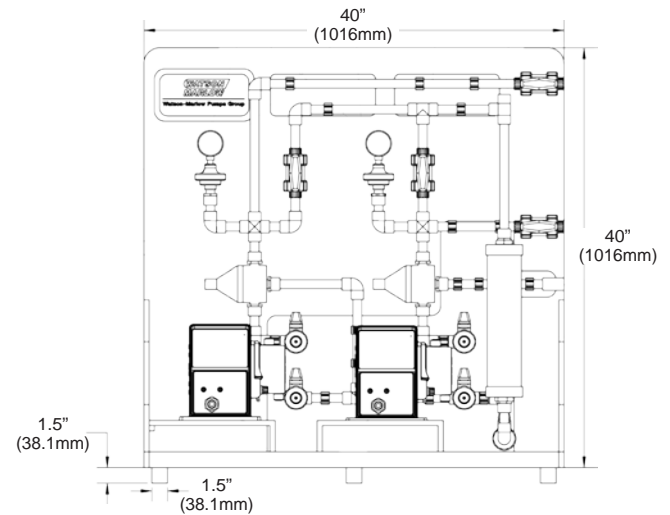
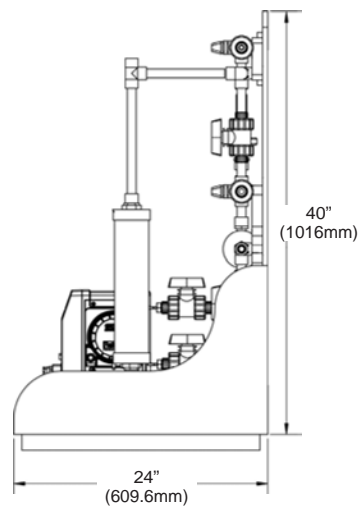
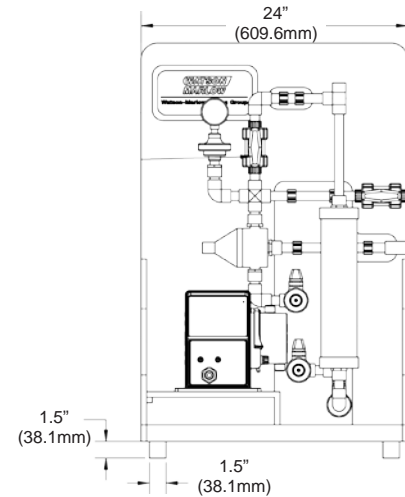
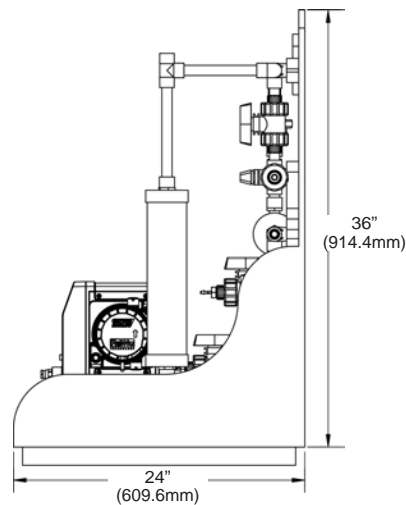

Watson-Marlow's Chemical Metering Systems are fully customizable to meet any application need. Everything from triple pump skids, hose pump systems and more, are available on request.

By utilizing advanced 3D CAD modeling tools, coupled with over 50 years of pumping expertise, Watson-Marlow can deliver a custom metering solution designed to your exact specifications and needs.



Watson-Marlow Pumps Group

Watson-Marlow Pumps Group has six world-class factories supported by direct sales operations in 23 countries and distributors in more than 50 countries. For contact details visit our website:

www.wmpg.com

A Spirax-Sarco Engineering Company

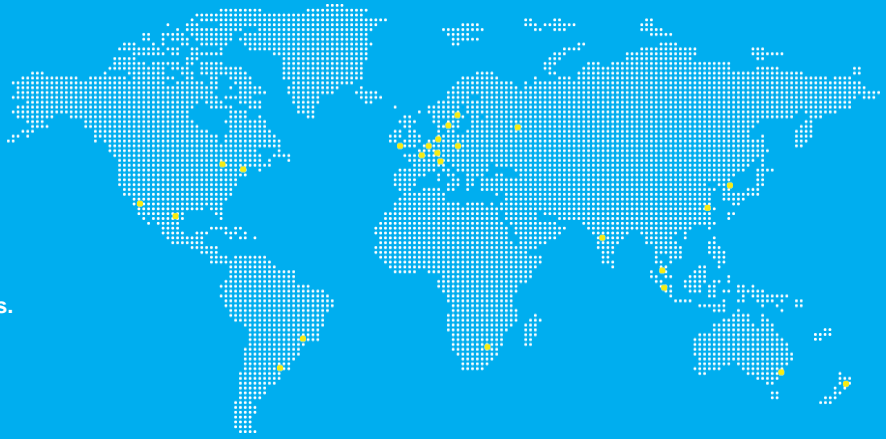

HB0457 | Issue 1

Watson-Marlow **Bredel** **Alitea** **Flexicon** **MasoSine**



Watson-Marlow online

Our engineers around the world can help you choose the perfect pump and tubing for your needs.

More information? Our brochures are on our website - www.wmpg.com

support@wmpg.us

Watson-Marlow... Innovation in Full Flow

Watson-Marlow Pumps Group

Watson-Marlow, Inc.
37 Upton Technology Park
Wilmington, MA 01887
Tel: 800-282-8823

Watson-Marlow, Inc. (West)
20992 Bake Parkway, Suites 100
Lake Forest, CA 92630
Tel: 855-567-9674

The information in this document is believed to be correct, but Watson-Marlow Pumps Group accepts no liability for any errors it contains, and reserves the right to alter specifications without notice. WARNING: These products are not designed for use in, and should not be used for, patient-connected applications. Watson-Marlow, is a registered trademark of Watson-Marlow Limited.

Copyright of Watson-Marlow Pumps Group 2013